

**OPERATING MANUAL
FLOOD SENSOR
FGFS-101-EN-A-v1.00**

Fibaro Flood Sensor is a universal, Z-Wave compatible, flood and temperature sensor. Device can be battery (ca. 2 years battery life) or VDC powered (12 or 24 VDC). Flood alarm is sent to the Z-Wave network devices or additionally to any alarm system controller, through opening a NC contact.

The device has built in temperature sensor, monitoring temperature of e.g. floor. Fibaro Flood Sensor is designed to be placed on the floor or on a wall with a flood sensor probe extended by connected wire. The device has built in LED indicator and acoustic alarm. In addition, the sensor is equipped with a tilt sensor reporting tilt or movement to the main controller e.g. when someone has taken the Sensor from its original location. LED diode signals flood, operating mode or the Z-Wave network communication range. Fibaro Flood Sensor is sink-proof, which means it drifts on the water surface and keeps on sending alarm signal in case of substantial inundation of water.

SPECIFICATIONS

Power Supply:	12 - 24 VDC
Battery Type:	CR123A
Power Consumption (at VDC operation):	0,4W
Output terminals maximum current carrying capacity (ALARM NC, TAMP NC):	25mA
Maximum voltage at output terminals:	24V DC / 20V AC
EU standards compliance:	EMC 2004/108/EC R&TTE 1999/5/WE
Radio protocol:	Z - Wave
Radio frequency:	868,4 MHz EU; 908,4 MHz US; 921,4 MHz ANZ; 869,2 MHz RU;
Range:	up to 50m outdoors up to 30m indoors (Depending on terrain and building structure)
Operational Temperature:	0 - 40°C*
Measured temperature range:	-20 to 100°C
Temperature measuring accuracy:	0,5°C (within 0 - 40°C range)
Dimensions (Diameter x Height):	72 x 28 mm
* Operational temperature in VDC powering mode: -20°C - 70°C	

TECHNICAL INFORMATION

- Compatible with any Z-Wave network controller,
- May be connected to any alarm system (potential free output terminal),
- Extremely easy installation - simply put on a surface prone to flooding,
- May be installed anywhere - flood sensor's contacts extended with a wire,
- Battery or VDC powered. When connected to an external, VDC power source, the battery serves as an emergency power source,
- Theft protection - tilt is reported to the Z-Wave network or alarm system's main controller,
- Two operating modes - flood / temperature sensor or just a temperature sensor.

I. GENERAL INFORMATION ABOUT FIBARO SYSTEM

Fibaro is a wireless system, based on Z-Wave technology. Fibaro provides many advantages when compared to similar systems. In general, radio systems create a direct connection between the receiver and transmitter. However, the radio signal is weakened by various obstacles located in its path (apartment walls, furniture, etc.) and in extreme cases it fails to transfer required data. The advantage of Fibaro System is that its devices, apart from being transmitters and signal receivers, also duplicate signal. When a direct connection path between the transmitter and the receiver cannot be established, the connection may be achieved through other intermediate devices.

Fibaro is a bi-directional wireless system. This means that the signal is not only sent to the receivers but also the receivers send the confirmation of its reception. This operation confirms their status, which checks whether they are active or not. Safety of the Fibaro System transmission is comparable to the safety of transmission in data bus wired systems.

Fibaro operates in the free bandwidth for data transmission. The frequency depends on radio regulations in individual countries. Each Fibaro network has its own unique network identification number (home ID), which is why it is possible to co-operate two or more independent systems in a single building without any interference.

Although Z-Wave is quite a new technology, it has already become recognized and officially a binding standard, similarly to Wi-Fi. Many manufacturers in various industries offer solutions based on Z-Wave technology, guaranteeing their compatibility. This means that the system is open and it may be extended in the future. Find more information at www.fibaro.com.

Fibaro generates a dynamic network structure. After Fibaro System is switched on, the location of its individual components is automatically updated in real-time through status confirmation signals received from devices operating in a "mesh" network.

II. Z-WAVE NETWORK INCLUSION

Use TMP button to include the Fibaro Flood Sensor into the Z-Wave network. In addition, the device may be included into the Z-Wave network in auto inclusion mode, at connecting a DC power source (mode active only after the built in battery has been disconnected).

Including the Fibaro Flood Sensor using auto inclusion mode:

- 1) Make sure a DC power source is disconnected and the sensor is located within direct communication with the main controller's range. The battery must be removed.
- 2) Open the cover.
- 3) Set the main controller into the learning mode (see a main controller's operating manual).
- 4) Connect a DC power source to include the Fibaro Flood Sensor into the Z-Wave network in autoinclusion mode.
- 5) Fibaro Flood Sensor will be detected and included.



NOTE

In case the Sensor is not detected, proceed to the manual inclusion (described below) or reset the Sensor and repeat auto inclusion procedure.

To deactivate auto inclusion mode, press TMP button once, after the Fibaro Flood Sensor has been connected to a DC power supply.

Manual Z-Wave network inclusion:

- 1) Connect a DC power supply to the Fibaro Flood Sensor or insert a battery. Make sure the sensor is located within the Z-Wave network's main controller's range (see main controllers operating manual).
- 2) Set the main controller into the learning mode.
- 3) Triple click TMP button.
- 4) Fibaro Flood Sensor will be detected and included.

III. Z-WAVE NETWORK EXCLUSION

Complete the following steps to exclude a Fibaro Flood Sensor from the Z-Wave network:

- 1) Remove sensor's cover.
- 2) Make sure sensor is connected to a battery or a DC power supply.
- 3) Set a main controller into learning mode (see main controllers operating manual).
- 4) Triple click TMP button, located inside Flood Sensor's casing.

IV. SENSOR'S INSTALLATION

- 1) Remove top cover.
- 2) Include into the Z-Wave network (see pt. II).
- 3) Place sensor onto a surface prone to flooding. All three electrodes underneath the device should evenly touch the surface.
- 4) If the sensor is to be DC powered, drill holes in it's casing and connect wires observing the wiring diagram no.2.
- 5) Close sensor's casing.



NOTE

After completing installation it's recommended to test sensor's operation by placing the entire sensor or it's probes' extension wire onto water surface.



NOTE

The Sensor detects resistance (under 4MΩ) between electrodes 1 and 3, 1 and 2 (according to scheme no.4), and electrodes connected to contacts (SENS1 and SENS2).



NOTE

Contacts SENS1 and SENS2 are dedicated to flood detection only. Do not connect external voltage.



NOTE

When changing the Sensor's location, it's recommended to wake up the device and reconfigure the Z-Wave network by triple clicking the TMP button.



NOTE

The TMP button has two functions:
1) Including / Excluding the device into / from the Z-Wave network.
2) Tamper contact for Ii-nd Association Group. When a sensor is included into the Z-Wave network, case opening alarm may be activated (according to parameter 74 settings).

V. POWERING MODE INFORMATION

There are two powering modes for the Fibaro Flood Sensor. By default it's powered by a factory included battery. In addition it can work with a constant current, after connecting a 12 / 24 VDC power supply to +12 and GND terminals (see diagram no.2). Powering mode configuration is carried out automatically, while a sensor is being included into the Z-Wave network. When battery powered, a Fibaro Flood Sensor communicates with a Z-Wave network main controller periodically. Detected alarms are sent immediately, but configuration parameters and associations settings only at specified wake up intervals, or at a manual wake up (TMP triple click). In DC powering mode, configuration and associations parameters are sent when necessary, and in addition a sensor serves as a Z-Wave signal repeater.

Switching to a constant current powering mode:

- 1) Exclude a sensor from the Z-Wave network.
- 2) Connect constant current power source (12 / 24 VDC) to +12 and GND terminals observing wiring diagram no.2.
- 3) Include the Fibaro Flood Sensor into the Z-Wave network.

In constant powering mode a sensor may operate without a battery. Installing a battery is recommended though, as it will serve as an emergency power source. When constant power fails, sensor will automatically shift to an emergency mode. All reports, including flood and temperature, will be sent immediately, but it will not be possible to modify the configuration or association settings until constant power returns. If a sensor served as a signal repeater for other Z-Wave devices, in emergency mode signal repeating function will be deactivated.



NOTE

Fibaro Flood Sensor will automatically exit emergency mode once 12/24 VDC at +12 and GND terminals is detected (according to diagram no.2) and the device wakes up after detecting an event, i.e. flood alarm, temperature report, tilt, or manual wake up using TMP button.

BATTERY TIPS



Fibaro Flood Sensor's battery life is ca. 2 years at factory default settings. The current battery level is displayed in a Home Center 2 interface. Red battery icon means a battery needs replacement. In order to avoid triggering tamper alarm while replacing the battery, Ii-nd association group's associations must be deleted, and Sensor's parameters' configuration set to default. Alternatively, the Sensor may be powered by VDC power source (12 / 24 VDC in accordance with a wiring diagram no.2) - in such a configuration, a battery will serve as an emergency power supply.



NOTE

Mounting screws shown in a diagram no.3 are not included in the package. Choose a screw type depending on the building material it is being attached to.

DIAGRAMS' DESCRIPTION:

- +12V** - 12 / 24 VDC positive terminal
- GND** - negative (ground) terminal
- ALARM NC** - potential-free flood sensor terminals (for wired systems)
- TAMP NC** - potential-free tamper terminals (for wired systems)
- SENS1, SENS2** - flood sensor electrodes' terminals.



NOTE

ALARM NC and TAMP NC connectors may be used as EOL protective loop's terminals.

VI. FIBARO FLOOD SENSOR RESET

Reset procedure deletes EPROM's memory, including all information on the Z-Wave network and the main controller.

Fibaro Flood Sensor's reset procedure:

- 1) Make sure the Sensor is powered.
- 2) Press and hold a TMP button for 15 - 20 seconds. LED indicator glows yellow to confirm entering 4th sub-menu.
- 3) Release the TMP button.
- 4) Click the TMP button, once.

The LED indicator glowing red and then turning off will confirm a successful reset. Reset completion will be confirmed by an acoustic signal, same as at the power source connection.



NOTE

Reset procedure doesn't remove the Sensor from the Z-Wave network's main controller memory. Prior to reset, a sensor must be deleted from the Z-Wave network.

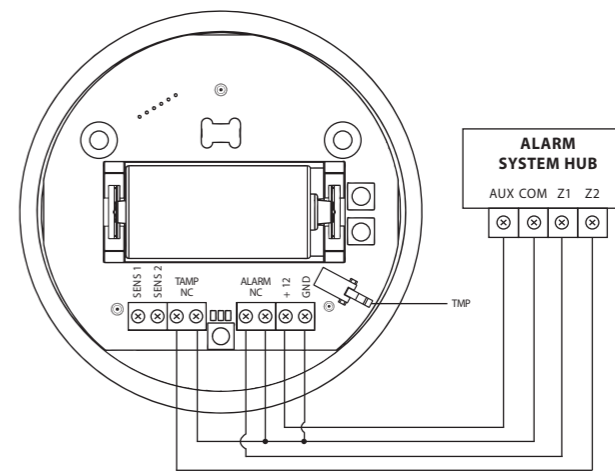

Fig. 1 - Connection with alarm system

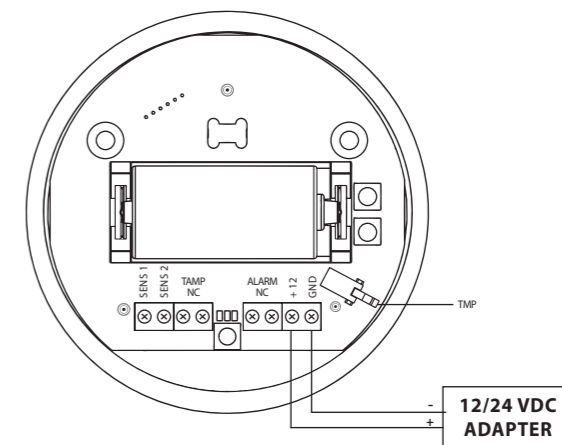

Fig. 2 - Connection to a constant power source

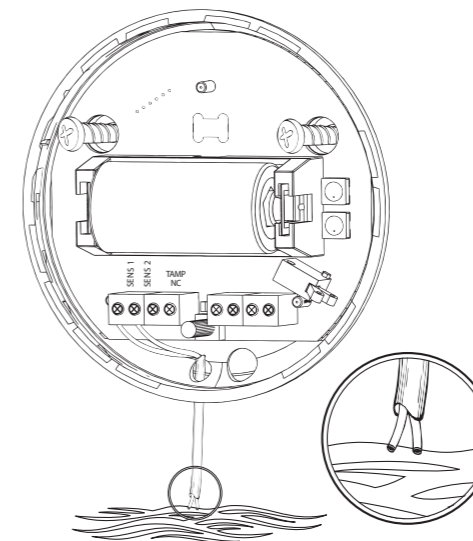

Fig. 3 - Flood sensor's contacts extended with a wire

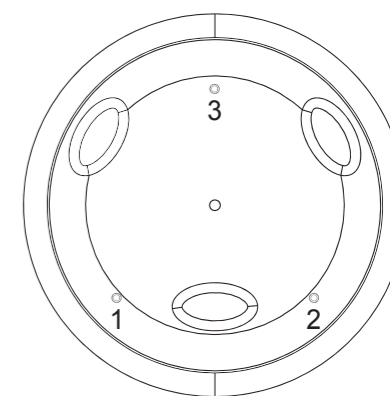

Fig. 4 - Probes marking

